



All works shown have used Right Angles in their construction

Product guide

Right Angles is a unique kit which allows the easy and fast build of all 90° corner shapes. Right Angles gives clean, precise corners and neat chamfers for reinforced concrete structures while ensuring consistent and high quality results every time.

- Major cost and time savings
- Consistent high quality results guaranteed, time after time
- Innovative new product, with green credentials, cuts waste and is reusable

Component list

Our products are available in the following pack sizes...

Part No.	Qty	Description
01	20	Tri Form
02	20	External Dual Form
03	20	Internal Dual Form
04	20	Tri Form without nailing flange
05	20	External Dual Form without nailing flange
06	20	Internal Dual Form without nailing flange
07	100	Jointing Piece
08	20	End Cap
09	2.44m lengths x 10 per pack	Extrusion with flange
10	2.44m lengths x 10 per pack	Extrusion without nailing flange
11	330	Duplex nails (500g)

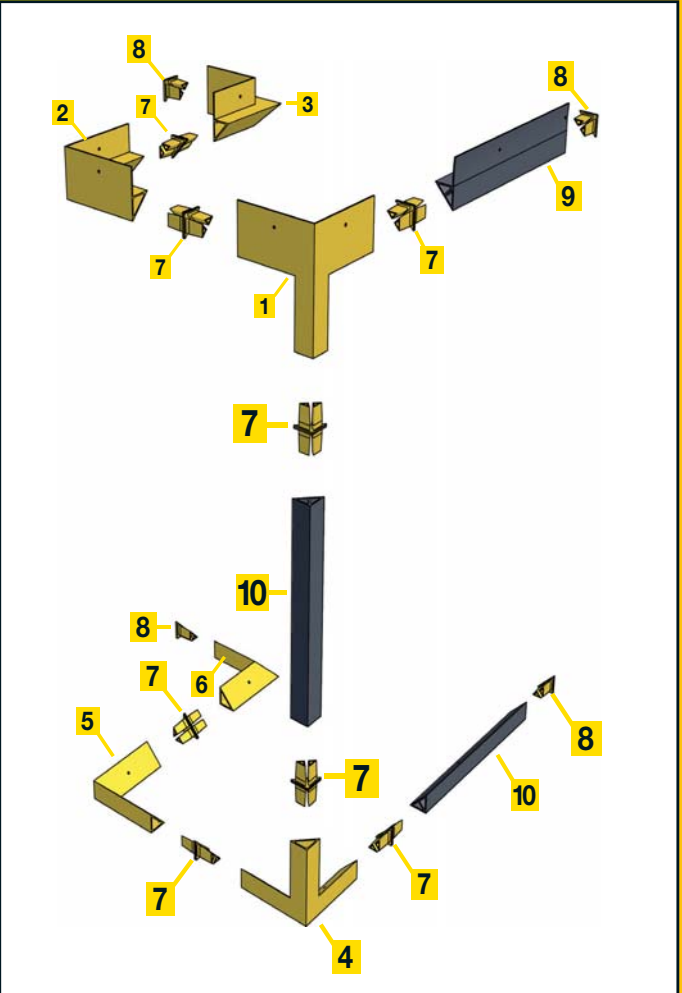

Benefits

- ✓ Produces a consistently smooth and accurate finish
- ✓ Re-usable - reducing environmental impact
- ✓ Time saving, fast, easy installation
- ✓ Reduces waste, material, installation time and remedial works
- ✓ Radius nailing flange reduces grout loss
- ✓ All components manufactured to ISO 9001
- ✓ Only cutting to length required reducing hand injury risks
- ✓ Made in the UK and fully recyclable

Specialist nails

Double headed for easy removal

